

Dagstuhl Seminar  
on  
Social Science Microsimulation:  
A Challenge to Computer Science

Organized by:

Jim Doran (University of Essex, UK)  
G. Nigel Gilbert (University of Surrey, UK)  
Ulrich Mueller (Universität Marburg)  
Klaus G. Troitzsch (Universität Koblenz)

Schloß Dagstuhl, May 1–5, 1995

## Contents

<b>1</b>	<b>Motivation</b>	<b>5</b>
<b>2</b>	<b>Final Seminar Program</b>	<b>6</b>
<b>3</b>	<b>Abstracts of Presentations</b>	<b>8</b>
3.1	Social Science Microsimulation / Microanalytic Simulation Models . . . . .	8
3.2	Social Science Multilevel Simulation . . . . .	11
3.3	Cellular Automata . . . . .	16
3.4	Game and Decision Theory . . . . .	18
3.5	Distributed Artificial Intelligence . . . . .	21
<b>4</b>	<b>Summaries of Informal Discussions</b>	<b>25</b>
4.1	Environments and Languages to Support Social Simulation <i>Summary by Nigel Gilbert</i> . . . . .	25
4.2	Computer Simulation and Social Sciences: On the Future of a Difficult Relation <i>Summary by Klaus G. Troitzsch</i> . . . . .	26
<b>5</b>	<b>List of Participants</b>	<b>27</b>

# 1 Motivation

Microsimulation in the social sciences, i.e. the simulation of dynamic feedback (in both directions) between individual states and states of the population as a whole or certain groups within a population, as well as dynamic feedback between the individuals and the emergence of new phenomena on the group or population level is still a task which suffers from at least three deficiencies:

- Either a model is straightforwardly described in a high level simulation language (like DYNAMO for the Systems Dynamics Tradition, or MIMOSE for younger concept based microsimulation approaches), then large scale models which a great number of interacting individuals cannot be run efficiently (in the case of MIMOSE and also in SmallTalk based multi agent models) or are impossible or extremely difficult (DYNAMO).
- Or a model can be run efficiently with a large number of individuals, then it must have been written down in a general purpose language and is only difficult to communicate in its details, as is the case with most data driven microsimulation models (as, e.g. the models of Sonderforschungsbereich 3 or the Darmstadt Micro Macro Simulator).
- In the second case there are at least two different traditions (of course, very short traditions): data based dynamical microsimulation with no or little interaction between the individuals, and the individuals regarded as black boxes behaving stochastically, and concept driven microsimulation models based on the distributed artificial intelligence approach, with the individuals modeled as agents with memory, goals, and rules, and acting in an environment. Both approaches have evolved in almost total ignorance of each other and a synthesis might be valuable.

Our plan is to discuss which solutions can be found (or developed) by computer science to the problems that arise from social science microsimulation in order that such models can be run efficiently from a user/modeler friendly surface by a modeler who wants to describe his/her model in a problem oriented language (like MIMOSE, e.g.), and not with the help of a general purpose language which is not communicable among social scientists.

The five days from May 1st to 5, 1995, were devoted to the following subjects:

- Social Science Microsimulation / Microanalytic Simulation Models
- Social Science Multilevel Simulation
- Cellular Automata
- Game and Decision Theory
- Distributed Artificial Intelligence

Participants included economists and social scientists applying microsimulation techniques of various different kinds as well as computer scientists interested in helping the former to solve their problems more elegantly and efficiently. Thus representatives of at least three different scientific communities gathered in order to discuss their problems and to help each other find solutions.

This booklet summarizes the presentations and the discussions during the seminar. A collection of long versions of most of the papers given is likely to be published in Springer's Lecture Notes in Economics and Mathematical Systems in late 1995 or early 1996.

## 2 Final Seminar Program

**Monday, May 1st, 1995**

**Session 1:** Social Science Microsimulation / Microanalytic Simulation Models

*Chair: Klaus G. Troitzsch*

**Hans-Dieter Heike:** Comparative Evaluation of the Implementation of Micro Simulators in 4GL and Object-Oriented Development Environments (with a presentation by **Thomas Sauerbier and Harald Ritz**)

**Heinz P. Galler:** The Halle Model: Fundamentals of a New Version of the Dynamical Micro Simulation Model

**Joachim Merz:** Concept, Realization, and Application of MicSiM — A PC Microsimulation Model for Research and Teaching

**Hiltrud Niggemann:** Microsimulation of Enterprise Data

**Georg Müller:** Exploring and Testing Theories: A Challenge for Social Science Microsimulation

**After Dinner Lecture:**

**Edmund Chattoe:** Why are we simulating anyway? Some Answers from Economics

**Tuesday, May 2, 1995**

**Session 2:** Social Science Multilevel Simulation

*Chair: Nigel Gilbert*

**Klaus G. Troitzsch:** Multilevel Simulation

**Michael Möhring:** Social Science Multilevel Simulation with MIMOSE (with presentation)

**Nicole J. Saam:** Multilevel Modelling with MIMOSE: Experience from a Social Science Application

**Rolf Grützner:** Individual-Oriented Simulation: Applications and Problems

**Dirk Helbing:** Master Equation, Path Dependent Quantities and Survival Analysis

**Péter Molnár:** A Microsimulation Tool for Social Force Models

**Allan Mazur:** Evolution in Humans of Macro-level Social Stratification and Language

**Informal Discussion:** Environments and Languages to Support Social Simulation

*Chair: Nigel Gilbert*

**After Dinner Lecture:**

**Bernd Schmidt:** Object-oriented specification of simulation models

**Wednesday, May 3, 1995**

**Session 3:** Cellular Automata

*Chair: Ulrich Mueller*

**Rainer Hegselmann:** Modeling social dynamics by cellular automata

**Oliver Kirchkamp:** Spatial Evolution of Automata in the Prisoner's Dilemma

**Afternoon Excursion**

**After Dinner Lecture:**

**Bibb Latané:** Simulating the Temporal Evolution and Regional Differentiation of Culture

**Thursday, May 4, 1995**

**Session 4:** Game and Decision Theory

*Chair: Nigel Gilbert*

**Wim Liebrand:** Game Theory, Decision Making, and Computer Simulations

**Daniel Probst:** Automata, Complexity, and the Evolution of Cooperation

**Andreas Flache:** Informal Social Control in Small Groups: A Micro Simulation Study

**Achim Sydow:** Parallel Simulation of Distributed Systems: Ozone Analysis

**Ulrich Mueller:** Finding Optimal Life Courses with Stochastic Dynamic Programming

**Informal Discussion:** Computer Simulation and Social Sciences: On the Future of a Difficult Relation

*Chair: Georg Müller*

**After Dinner Lecture:**

**Ramzi Suleiman:** Towards a refined simulation of cooperation and competition

**Friday, May 5, 1995**

**Session 5:** Distributed Artificial Intelligence

*Chair: Ulrich Mueller*

**Jim Doran:** Simulating Societies Using Distributed Artificial Intelligence

**Rosaria Conte:** Simulating multi-agent interdependencies. A two-way approach to the Micro-Macro link

**Klaus Manhart:** Artificial Intelligence Modelling: Data Driven and Theory Driven Approaches

**Adeline Uhrmacher:** Object-Oriented and Agent-Oriented Simulation: Implications for Social Science Application

**Concluding Talk:**

**G. Nigel Gilbert:** Simulation as a Research Strategy

### 3 Abstracts of Presentations

#### 3.1 Social Science Microsimulation / Microanalytic Simulation Models

##### 3.1.1 *Hans-Dieter Heike, Kai Beckmann, Achim Kaufmann, Harald Ritz, and Thomas Sauerbier:* **Comparative Evaluation of the Implementation of Micro Simulators in 4GL and Object-Oriented Development Environments**

A short introduction into the nonlinear, complex stochastic structure of the Darmstadt Micro Macro Simulator (DMMS) is followed by some applications of the household and the enterprise sector.

The DMMS is implemented by means of the two paradigms of software engineering: the 4GL structured system development and the object-oriented system development. Characteristics of 4GL systems are shown and the architecture of the 4GL DMMS is presented. Special features of the 4GL DMMS application development environment are automatic tools for database and program generation: the Darmstadt Database Generator (DDBG) and the Darmstadt Program Generator (DPG). The Darmstadt Runtime Monitor is used for physical database optimization, which results in significant runtime reduction. A source code example shows i.a. the call structure from main to bottom, subprograms, the subdivision between user interface, application and database management.

Contrary to the structured system approach the OO system development uses a unifying approach from requirement definition to implementation. Characteristics of the OO approach in software engineering are shown and the architecture of the ODMMS is introduced in order to show structured differences between the paradigms in question. The differences are apparent also in the source code example.

The 4GL structured system development had been introduced to enhance programming productivity and the main aim of OO-approach was to strengthen the stability of software products by using stable objects defined in practice. In order to evaluate both approaches it has to be decided e.g. whether functionality or data structure of the 4GL or the objects of the OO-paradigm are the most stable parts of an actual system. In any case runtime behaviour of the chosen OO-language Smalltalk is not satisfying i. a. because of the dynamic binding. On the other side time consumption of the 4 GL NATURAL can be reduced to the level of a 3GL by optimizing.

##### 3.1.2 *Heinz P. Galler:* **The Halle Model: Fundamentals of a New Version of the Dynamical Micro Simulation Model**

The HALLE dynamic microsimulation is a completely revised version of the model that had been developed at the Sonderforschungsbereich 3 at the University of Frankfurt in 1975–1986. Due to the discrete time transitional approach with a recursive structure of transformations, it is difficult to adapt this model to more advanced model structures that have been developed in the meantime. This is especially true for dependencies between different processes considered for a micro unit as well as for dependencies between different micro units. In addition, the simulation software that had been designed about 1975 proved to be too complex and inflexible and difficult to adapt to new demands. This is especially true for the user interface that had not been very user friendly. Therefore, a basic revision of the whole model including the basic simulation concept and the software design has been started.

The new HALLE version is based on a continuous time process oriented design with an event driven simulation of the micro units. Conceptually, each individual micro unit is represented by a set of processes that are simulated in parallel. Events that change the state of one process are communicated to the other processes that are interrupted. Depending on the type of the event and

the specific process, the consequences of the event for the further simulation are taken into account and then the simulation of the different processes is restarted. In this way, dependencies between processes can be taken into account in a flexible way.

Since the basic structure of the simulation has strong similarities to modern multi-process operating systems, software solutions that have been developed for operating systems can be applied. Thus, efficient solutions can be found more easily. Also, an attempt is made to design the simulation software in such a way that parallel processing of the micro units on multiprocessor platforms will become possible in the future. However, on the current stage, the efficiency of different solutions and its implementation still are to be evaluated in detail.

### **3.1.3 Joachim Merz: Concept and Realization of MICSIM — A PC Microsimulation Model for Research and Teaching**

MICSIM is a microsimulation model development to overcome former problems of handling larger microsimulation models in a protected, more efficient and easier way to use.

Based on economic and social science microsimulation (MS) experiences within the Sfb 3 'Microanalytic Foundation of Social Policy' of Frankfurt and Mannheim Universities, the new FFB MICSIM model is concentrating on the three most important MS tasks: *Simulation* (as the main purpose by parameter variation), *adjustment* (finding new microunit weights which simultaneously weight each vector of household characteristics where the weighted sum of characteristics finally fits to new given aggregates; those aggregates may be future demographics or different demographic situations for sensitivity analysis), and *evaluation* (MICSIM statistics, support access for SPSS, other statistical packages like INEQ: inequality measures). In addition an advanced user might use SQL for any direct access to the data.

A relational data base system (ORACLE) is our microdata base. SQL allows a protected, integer and set-theoretical access to only those data which are of actual simulation interest. Visual C++ is the overall programming language which allows graphical interaction under WINDOWS and access via a precompiler to SQL (PLUS). MICSIM is therefore a general microdata handling tool with an easy to use interface both for research and teaching.

### **3.1.4 Hiltrud Niggemann: Firm size: A longitudinal process. Microsimulation of Enterprise Data**

Microsimulation in social science may be used in very different ways. The following gives an example of microsimulation as a tool for exploring and testing theory.

The empirical analysis in our research project which is interested in the social, economical, organizational and technical development related to flexible worksystems often shows a significant but not always linear or at least monotone effects of the size of a firm. To get more detailed knowledge of the meaning of firm size and the underlying dimension one may think about firm size as a longitudinal process which is the result of the attempt to organize and structure the tasks in a firm by the use of an adequate control and coordination system. The amount of tasks is on the one hand determined by the quantity and heterogeneity of products and on the other hand it is influenced by the number of employees. In dependence of the chosen control and coordination system and the general economic development the factors number of employees and amount of tasks are changed period by period to get a process describing the growth and death of firms. The final aim is to check whether one can find in this dynamic process any combinations of firm size and control and coordination system which lead to a higher probability of firm survival than other solutions do.

### 3.1.5 Georg Müller: Exploring and Testing Theories: A Challenge for Social Science Microsimulation

Thesis 1: Computer simulation is a *potentially powerful tool* to test and explore *new* theories about the dynamics of a sociological state variable  $x(t), t = 0, 1, 2, \dots$ . By variation of the parameters  $c$  and the initial condition  $x(0)$  of an appropriate simulation model it is possible to study the theoretical implications of the model and to test it with observational data.

Thesis 2: *Tuning by hand* of model parameters is difficult and time consuming. Since only a very limited number of combinations of parameter values can be checked, the results of this type of parameter tuning are generally not satisfactory.

Thesis 3: To avoid the problems mentioned in thesis 2 we propose to automatize the tuning of model parameters by means of an *optimization procedure*: It iteratively changes the values of the parameters  $c$  and the initial conditions  $x(0)$  such that a task specific *target function*  $T(c, x(0))$  is optimized.

Thesis 4: For *empirical tests* of the correspondence between theory and data we propose to define the afore mentioned target function  $T(c, x(0))$  as a sum of the weighted differences between the simulated time series  $x(t), t = 0, 1, 2, \dots$  and the corresponding data: If  $T(c, x(0))$  becomes sufficiently small for appropriate  $c$  and  $x(0)$ , the new theory behind the model is considered to be confirmed.

Thesis 5: In order to study the *general validity* of a particular *theoretical implication* of a model we propose to search for initial values  $x(0)$  and parameters  $c$  for which this implication does *not hold*. For this purpose we have to minimize a target function  $T(c, x(0))$  which is defined as the *degree of validity* of the studied implication, e.g. in terms of a *correlation* between two *simulated* variables  $x_i(t), t = 0, 1, 2, \dots$  and  $x_j(t), t = 0, 1, 2, \dots$ . If it is *not possible* to make the minimum of this target function  $T(c, x(0))$  sufficiently small, the implication of the model can be considered as generally valid.

Thesis 6: The optimization of the afore mentioned target functions requires *sophisticated algorithms*. Ideally they should be able to minimize nonlinear target functions with undefined gradients and numerous constrained model parameters. For efficient work with such algorithms the use of *powerful computers* is a must.

Thesis 7: Most of the older simulation languages such as DYNAMO or CSMP require hand tuning of parameters in order to study the behavior of a model. Hence a *new generation* of simulation software is needed which offers its users optimization tools in order to test and explore their theories.

### 3.1.6 Edmund Chattoe: Why are we simulating anyway? Some Answers from Economics

This research is part of Project L 122-251-013 funded by the ESRC under their Economic Beliefs and Behaviour Programme.

This paper considers two aspects of the simulation of social systems. Firstly, it investigates the meaning of the term “simulation” as it is typically used by economists. This economic interpretation then suggests a distinction, between simulating a theory and simulating the world, that is useful in providing a more general description of the usefulness of simulation. Once it is recognised that the mathematical representation of a theory is only one of a number of possible representations, it is possible to compare the relative merits of representations for different objectives of social science. The paper suggests a number of difficulties with a mathematical representation in a theory of social action and suggests that a simulation representation can address them, thereby “encompassing” the mathematical representation. The paper also considers



some of the objections that economists commonly make to the simulation process and suggests ways in which these can be overcome. In some cases, overcoming these objections amounts to no more than observing that they are themselves based on unsupported arguments about the tasks and methods of social science. Finally, the paper suggests that the simulation approach may actually prove more amenable to the sort of “scientific rigour” to which economic theory aspires because it provides a complex “public” object for examination and criticism, in the form of the simulation programme.

## 3.2 Social Science Multilevel Simulation

### 3.2.1 Klaus G. Troitzsch: Multilevel Simulation

In this paper, we consider why formal modeling — including both mathematical analysis and computer simulation — did not make a substantial contribution to the development of social science, although it has a tradition of at least four decades.

We shall consider these efforts within a realm of science dealing with systems of high complexity undergoing changes in time or, to formulate it the other way round, dealing with processes going on in complex systems, and discuss what has to be added to the common practice of formal modeling to make it successful in contributing to the progress of social science.

We will discuss mathematical and simulation aspects of three examples of dynamical modelling in the social sciences which seem to be good examples for the multilevel simulation approach and at the same time show how a deeper understanding of empirically observed processes can be achieved by means of simulation:

- a simple, but famous model of the process of opinion formation — a stochastic model in discrete state space with feedback between the individual and the population level,
- a model of attitude formation — a stochastic model in continuous state space, also with feedback between the individual and the population level (individuals “move” in attitude space according to the gradient of their density, at the same time changing this density),
- a model of gender desegregation in schools, again a stochastic model in discrete state space with feedbacks between three levels.

Widely spread modelling procedures seem to consist of several steps, where the first step is the identification of some part of reality as a “real system” consisting of elements of different “natural kinds” and their representation by model objects. In a second step we have to identify relations defined on the “natural kinds” of these elements (“what depends on what?”), and in a third step we identify their properties and represent them by model object attributes. In a fourth step we detect — or rather reconstruct — the laws governing that part of reality we are about to model (“what are the dependences like?”). In the fifth step we have to combine our notions of the laws governing reality into a model. The sixth and last step consists in playing the game (in gaming-simulations), solving the equations (in purely mathematical models), or in running the simulation program (in the case of computer simulation).

The close kinship between mathematical models and most of the computer simulation approaches discussed above (save perhaps the multi-agent or distributed artificial intelligence approach) leads to some concluding remarks which should warn against the abuse of modelling and simulation results.

After all we know from catastrophe and chaos theory, quantitative prediction may turn out impossible even when a deterministic model may seem appropriate; measurement of initial conditions and of parameters is never so perfect as to guarantee that the real process follows the same

path as the modelled process. But in both cases a qualitative prediction is possible (and valuable) since we are in a position in which we can predict whether a real process is likely to behave predictably or not — this, of course, necessitates nonlinear modelling since linear models always yield quantitative predictions.

In the case of nonlinear stochastic simulation, another caveat is in order. Computer simulation does not yield more than one (or at most a few) realizations of a stochastic process, and — in contrast to the case of linear models — we may never be sure that these realizations are near a maximum likelihood path.

Thus, whoever makes use of simulation to contribute to the solution of socially or politically relevant questions should be aware and make his or her audience aware that simulation is never more than the solution of a formal model for a given parameter vector and a given set of initial conditions (both of which have to be justified), and that stochastic simulation is even less: one single realization of a stochastic process. Simulation tools should not only make this awareness possible, they should promote and, even better, enforce it.

### 3.2.2 Michael Möhring: Social Science Multilevel Simulation with MIMOSE

This paper gives an overview of the modelling and simulation system MIMOSE (*MI*cro- and *MO*ultilevel *SO*ftware), which consists of a model description language and an experimental frame for the simulation of models. The main purpose of the MIMOSE project was the development of a modelling language which considers special demands of modelling in social science, especially the description of *nonlinear, quantitative and qualitative relations, stochastic influences, birth and death processes*, as well as *micro and multilevel models*. At the same time, describing models in MIMOSE should not burden the modeler with a lot of programming and implementation details. Furthermore, the language concept should support the development of structured, homogeneous simulation models, which improves the transparency of the “model programming process” and makes model descriptions and even the corresponding simulation results easier to understand.

To reach these goals MIMOSE is based on the following:

- Ideas from *general systems theory* are adapted to achieve a general and uniform modelling technique.
- The language structure of MIMOSE is strongly influenced by the paradigms of *functional programming languages*. Because of its declarative, uniform language concept, functional programs are easier to understand, and more implementation independent than programs written in procedural programming languages.

This leads to the following main characteristics of MIMOSE models: Referring to the *structure*, each MIMOSE model consists of a set of object types, from which concrete objects will be created during the model initialization. Objects, as formal representations of entities in reality (i.e. individuals, groups, or organizations) are structured by a set of attributes, which are formal representations of real properties (i.e. age or attitude). Referring to the model *behaviour*, the values of all object attributes at a given time represent the state of this object. Each object attribute can take a state transition function, which evaluates the attribute value in each simulation step. The behaviour of an object is defined as its state change over time.

Modelling and simulation with MIMOSE is demonstrated in detail by developing both a macro model and a multilevel model of the well known prey/predator model by Lotka and Volterra. Compared to the macro model, in which only the behaviour of the number of preys and the number of predators is defined by difference equations, the multilevel model describes the individual

behaviour of preys and predators on the micro level and its effects on the macro level as well as feedback effects from the macro to the micro level.

Actually we use MIMOSE quite successfully within the education of our students in modelling and simulation techniques. Further applications are migration and co-operation models as well as environmental and epidemic models in biology.

MIMOSE provides a powerful modelling language combined with a user friendly experimental frame for simulating and analysing models. Therefore, this approach can be seen as one step towards the development of more general modelling and simulation tools in social science.

### 3.2.3 *Nicole J. Saam*: **Multilevel Modelling with MIMOSE: Experience from a Social Science Application**

In order to validate a simulation model usually experiments are carried out. They verify the sensitivity of the simulation results due to small changes of the initial values of parameters and variables (“conventional sensitivity analysis”). Since only a very limited number of combinations of parameter values can be checked, tuning by hand generally results in incomplete overviews of the implications of the model.

A slightly simplified version of the semiquantitative sensitivity analysis which was developed by Vester (1991, 1990) was carried out using an available conventionally verified multilevel model (implemented in MIMOSE) in order to cross validate the incomplete results of the conventional sensitivity analysis.

It was demonstrated, that (1) it is necessary to substitute for Vester’s ordinal influence values, (2) that the application of his method on multilevel systems leads to the distortion of the sensitivity matrix. Nevertheless it should be tried to improve Vester’s semiquantitative sensitivity analysis to such a degree that we can compare and cross validate its results to those of conventional sensitivity analysis.

### 3.2.4 *Rolf Grützner*: **Individual-Oriented Simulation: Applications and Problems**

The main points of the following considerations are biological and ecological systems. Ecological research includes investigations of the properties of individuals, populations, and ecosystems. There is a hierarchical system structure: ecosystem — life community — population — individual. Investigations of the interfaces between these components require new approaches. There is a well-founded expectation that a progress of the causal explanation of properties at the next higher level of integration (hierarchical level) will be reached.

The relations between the levels of population and individuals are very important. In the ecological research there are some restrictions in using compartment models related to the level of population. This is the reason for the introduction of individual based models as a counterpart to the classical state models. An individual oriented model will be suitable for the representation of the high number of freedom degrees in natural systems. The dynamic behaviour of a system will then be the integrated behaviour of all of the single individual objects. For instance individuals can be single organisms of a population, the cell of a cancer, a tree of a special type in the totality of the trees of a forest, the vehicles of a traffic flow, the objects of an army (e.g. airplanes, tanks, companies).

General conditions for the applications of individual oriented simulation:

- only a small number of objects exists and a compartment model cannot be used, that means: a structure adequate model is only an individual oriented model.

- investigations of special problems which cannot be solved by compartment models (e.g. actions in small time instants).

Application fields in ecological domain are:

- investigation of ecological systems
- variability of ecological systems
- spatial and temporary variations of populations
- survival strategies
- energetic and informational aspects of the individual behaviour and of the connection of both aspects
- toxicant effects on individuals and on the global system.

The models of individuals must include more or less functions for self-organization, abilities of learning, growth. Sensors, reactive, and communicative mechanisms a priori functions of such models.

Object-oriented concepts are suited for the modeling of individual oriented systems. The object-oriented modeling concept must provide descriptive and functional components to deliver knowledge acquired in an evolutionary process to the following generation of individuals — the new carrier of the knowledge. This requires capacities for teaching and for learning.

An implementation of an individual based simulator concept to investigate the traffic flow in highways has been represented.

### 3.2.5 Dirk Helbing: Master Equation, Path Dependent Quantities and Survival Analysis

This paper presents and derives the interrelations between survival analysis and master equation. Both have important applications in the social sciences and other scientific fields treating *stochastic systems*. However, since they focus on different aspects of modeling, it seemed that they have nothing to do with each other.

*Survival analysis* deals with modeling the transitions between succeeding states of a system. Questions related with this are the *timing*, *spacing*, and *sequencing* of the states of a time series. Survival analysis tries to fit and understand the distribution of these quantities in terms of the functional form of the *hazard rates* which are responsible for the investigated transitions. The parameters specifying the concrete functional form of the hazard rates are normally estimated from empirical data by means of the *maximum- or partial-likelihood method*.

Once the hazard rates are known, the associated *master equation* can be solved. This allows to investigate the temporal evolution of the *distribution of states*. Consequently the master equation is suitable for the calculation and prognosis of *cross-sectional data* which are related with the longitudinal life-table data used for survival analysis.

However, a new solution method for the master equation also allows the calculation of path-dependent (i.e. longitudinal) quantities. Such quantities are the *occurrence probability* of a certain sequencing of states (path) and the *cumulative waiting time distribution* of a path.

These quantities facilitate the formulation of a *hidden state theory for behavioral changes* which allows an interpretation of the respective time-dependence of hazard rates. Hidden states represent states which are either not phenomenological distinguishable from other states, not externally measurable, or simply not detected. They could, for example, reflect individual predispositions, internal motivations, or attitudes towards a certain behavior.

### 3.2.6 Péter Molnár: A Microsimulation Tool for Social Force Models

A model for the behavior of pedestrians was developed on the bases of social forces. In this approach the impact from other pedestrians and the surroundings are described by forces that represent the best or most common change of the behavior of the individual they exert on. But in contrast to physics, social forces represent only a motivation to act.

Simulations that consider only two simple rules show self-organization patterns of pedestrians' flows we can observe in crowded pedestrian zones and subway stations.

1. In corridors with oncoming flows pedestrians with the same walking direction form groups.
2. At narrow passages where pedestrians try to go through from both sides, the passing direction changes rather regularly after a certain number of pedestrians.

Both phenomena of collective behavior stem from very individual-oriented rules: Each pedestrian wants to walk to his given destination with a desired speed. Each pedestrian keeps a certain distance to the others and to the surrounding boundaries and obstacles.

Due to the complex interactions, the pedestrians' flow depends sensitively on the geometric shape of the developed environment. Simulations have shown that an obstacle in the center of a concourse may improve the efficiency of the pedestrians' traffic significantly. These effects can be used to optimize pedestrians' facilities by systematic modifications of the shape and the layout.

The structure of the simulation program follows the concept of object-oriented programming. In order to gain a maximum calculation performance, the simulation objects are defined in C++ source code.

The toolkit contains some generic classes of actors that provide methods for parameter definition, calculation, and visualization. The properties of a new type of individuals can be specified in later derivatives of this classes. In many cases, only a few functions that define the impact of the new type to other individuals, and the change of the behavior in accordance to the exerting forces have to be redefined.

The simulation tool allows to assemble own models as well. Therefore, the composition of populations, the connection between the individuals, and the parameters of the model will be specified in a comfortable description language.

### 3.2.7 Allan Mazur: Evolution in Humans of Macro-level Social Stratification and Language

Chimpanzees and humans had a common ancestor as recently as five million years ago. The evolution of grammatical language in humans must be more recent, yet its complexity has been difficult to explain in terms of natural selection. Also since the chimp-human split, human societies have grown very large in size and are invariably based on macro-level social stratification, which is not known in other species. How did these features of human society evolve, and are they related? The models discussed here suggest that macro-level stratification is not a simple extension of the primate dominance hierarchy, as has often been suggested, but instead requires newly acquired behaviors, especially the ability to accumulate cultural or material assets and pass these on to the next generation. With the development of macro stratification, as societies grew in size, the ability to organized words into grammatical sentences, including subject-verb-object ordering and recursion, became adaptive.

### 3.2.8 Bernd Schmidt: Object-oriented specification of simulation models

*Object-oriented program design and implementation has two main features:*

- *independent model components*

- *non-procedural processing within the model*

These characteristics allow for a higher degree of similarity between the real system and its model.

Keywords: object-oriented model specification, object-oriented implementation, concurrency, graphical user interface for model specification.

According to the object-oriented approach the specification of a model proceeds step-wise, by firstly defining independent components which are interfaced at a later stage (see Fig.).

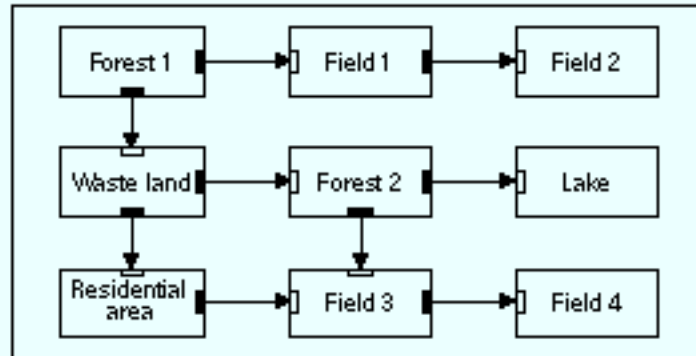

Fig.: An eco-system constructed from individual models

There are two requirements which an object-oriented specification should meet:

- Each component should result in a self-contained software process. This means that despite eventually becoming part of a larger system each building block should in itself be a model of some sort. Therefore, these models can be interfaced with each other thus becoming a larger, more comprehensive model on the next higher hierarchical level.
- The ordering of component specifications should have no influence on their run-time behaviour. This means that the resulting software system should be non-procedural. This characteristic poses a challenging design task when dealing with discrete events, or when processing sets of algebraic equations.

Object-oriented specification of models is based on the results of general systems theory, which makes the approach applicable in all domains of science be it for modelling technical, natural, economic or social systems.

We use an example from ecology to illustrate this: we are modelling some region consisting of lakes, fields, some wasteland area and residential areas. Each of these components is a self-contained, sustainable unit, irrespective of being embedded in a larger system.

The individual components can now be combined at will in order to create new, more complex systems.

This approach can also be applied in the social sciences. It offers a new way of describing real observable phenomena.

### 3.3 Cellular Automata

#### 3.3.1 Rainer Hegselmann: Modeling social dynamics by cellular automata

Cellular automata (CA) based models have been known for about fifty years. Today they are widely used in the natural sciences. What made them attractive is that in those models simple basic or micro structures very often induce complex dynamics with surprising macro effects, which are fascinating and hardly understandable in analytical terms. The type of problems which in other fields of science are successfully approached by using CA remain urgent and unresolved problems

in the social sciences. So it should not come as a surprise that within the social sciences we can find models which are CA in a literal sense or are at least based on the same spirit: Schelling analyzed segregation processes in a modeling framework which might be regarded as a CA. Sakoda used so-called “checkerboard models” to analyze group dynamics. But though known for several decades it is only the last couple of years that CA or checkerboard based models are used more frequently.

To give support for the assumption that CA are a powerful modeling concept one model is described in detail. The central question approached by that model is how networks of mutual support evolve in a world

- which is exclusively inhabited by rational egoists,
- who become needy with different probabilities;
- who can and must choose their partners themselves;
- who will choose their partners in opportunity taking ways.

The central idea is to model support relationships by a 2-person support game, which players will play simultaneously and independently from each other with all their neighbors. The individuals live in a 2-dimensional world. From time to time players have the chance for migration and they use those options to find better places in their world. As a consequence of that dynamics we get clustering and certain patterns of segregation. It turns out that those with a middle probability of becoming needy have the least difficulties to find partners. Another result is that despite all segregation, equality — measured in terms of payoffs — increases.

It should be stressed that the main purpose of CA based models is not to make quantitative predictions. It is rather clarification of concepts and qualitative understanding which makes CA based modeling a promising approach for understanding social dynamics.

### 3.3.2 *Oliver Kirchkamp: Spatial Evolution of Automata in the Prisoner’s Dilemma*

The paper applies the idea of evolution to a spatial model. In contrast with global models where a population of agents randomly plays against each other we consider a model where only neighbored agents play a game. Further evolutionary pressure (learning) is assumed to be local too.

An evolving population can thus be represented as a cellular automaton (see R. Axelrod, *The evolution of cooperation*, Basic Books, New York, 1984, and R. M. May and M. A. Nowak, Evolutionary games and spatial chaos, *Nature*, 359:826–829, 1992).

We allow players to distinguish between their neighbors. Strategies of a single player are modelled as identical small automata that may be in different states against different opponents. Players learn and thus change their strategy while remaining in uninterrupted interaction with their neighbor. One might suspect more complex strategies to forward a more rational and thus less cooperative outcome but it turns out that on the contrary more complexity allows for more cooperation.

Some strategies succeed in creating a favorable environment that allows them to exploit their neighbors successfully while ‘feeding’ them only occasionally. This long run inequality that never would arise in a global model decreases when stochastic learning is introduced and when players’ memory becomes larger.

We consider numerous different prisoners’ dilemma games and coordination games, different learning rules, stochastic initial configurations, neighborhoods of different sizes and networks in different dimensions. While behavior of cellular automata can sometimes be very unstable, properties like the long run amount of cooperation in prisoners’ dilemmas turn out to be stable, react in an intuitively predictable way on changes in parameters, and do not depend considerably on the initial state of the population.

Changing the dimension of the network seems to have no influence at all. Changing payoffs of a prisoners' dilemma such that costs of cooperation are increased, decrease in a predictable way the amount of cooperation. Also moving to more global models introducing larger and larger neighborhoods decreases smoothly the amount of cooperation until a non cooperative solution is reached. This is again what we should expect, since global evolutionary theory predicts a non cooperative outcome.

We further compare synchronous timing (as used both by Axelrod and by May and Nowak) with stochastic timing, studying the conditions under which stochastic timing might eliminate features of local learning like cooperative behavior. Natalie S. Glance and Bernardo A. Huberman (Evolutionary games and computer simulations, *Proceedings of the National Academy of Sciences*, 90:7716–7718, 1993) argue that stochastic evolution might eliminate cooperation in the prisoners' dilemma. While synchronous timing might be a dubious assumption, we find that cooperation persists with asynchronous evolution for a wide range of parameters.

### 3.3.3 *Bibb Latané*: **Simulating the Temporal Evolution and Regional Differentiation of Culture**

- 1 Exemplifying temporal evolution and regional differentiation, English accents exhibit four attributes of culture: the clustering, correlation, polarization, and stable diversity of elements.
- 2 According to a new theory of social impact, culture is the result of social interaction among spatially distributed individuals influencing each other on each element in proportion to their strength, immediacy, and number.
- 3 A new system for conducting multi-agent simulations of dynamic social impact theory shows the development of subcultures in groups:
  - a electronic juries demonstrate the emergence of clustering,
  - b a conformity game shows the importance of spatial geometry and the development of correlation,
  - c emergent conceptions of human rights discussion of six items from the middle of a 21 point scale of human rights lead to significant spatial clustering and the emergence of a general factor corresponding to the international consensus.

**Conclusion:** Just as silicon computers can be used to solve scientific and technical problems, e-mail networks can be used as computers for resolving political and moral issues.

**Question:** Can computer science help?

## 3.4 **Game and Decision Theory**

### 3.4.1 *Wim Liebrand*: **Game Theory, Decision Making, and Computer Simulations**

Game theory is a tool to study the interactions of ideally rational individuals in socio-economical contexts. It can aid our understanding of the behaviour of real individuals. Studying the former should aim at understanding the latter.

Game theory also has its problems. On the one hand there is a large discrepancy between observed and prescribed behaviour. On the other hand, the game theoretical requirements are too strict, and we are confronted with no or a multiplicity of prescribed strategies in the games that really matter.



Concepts like bounded rationality and retrospection are introduced as possible approaches to deal with these shortcomings. In this presentation a study is described in which cooperation sustained in an artificial world in which boundedly rational actors interacted with each other under prisoners' dilemma game contingencies, using highly competitive decision strategies.

Various computer simulations served as a tool to get a better grip on the complex decision making environment. As a result, several equilibria specifications could be formalized. We conclude that computer simulation provides a nice and effective method to aid our understanding of the behaviour of the real individual.

### **3.4.2 Daniel Probst: Automata, Complexity, and the Evolution of Cooperation**

In a first part this paper introduces two ideas on the evolutionary analysis of the Abreu and Rubinstein automaton selection game for the repeated prisoners' dilemma:

- an evolutionary process with a constant influx of simple mutants,
- a set valued evolutionary stability concept.

Such sets consist of automata which are indistinguishable in an evolutionary process in terms of repeated game payoff and complexity. A set will be called stable if no mutant from outside the set can intrude a population consisting of any distribution over the set. There happens to exist one unique set of five three-state automata fulfilling the above requirements.

A second part introduces a dynamic simulation of the above evolutionary process. The resulting population structure shows a high level of cooperation due to strategies which first signal with defection before entering the cooperative phase. Cooperative phases are punctuated by brief periods where cooperation breaks down. Theoretical arguments are given that this feature can be explained by drift in the selection process coupled with arrival times of mutants depending on the mutation process.

### **3.4.3 Andreas Flache: Informal Social Control in Small Groups: A Micro Simulation Study**

It is argued that micro simulation in the social sciences are particularly fruitful when applied as a tool to explore the consistency of theoretical explanations. As an example we discuss the process of informal control in small groups. Social exchange theory conceives of social control as an exchange of peer approval for compliance with group obligations. We formalize the social exchange model in terms of a Bush-Mosteller stochastic learning approach. Simulations confirm a central proposition of small group research : the higher the level of social cohesion in a group the more actors comply with a group obligation. It is then shown that this proposition hinges critically on the assumption that exchange of approval for approval is irrelevant for the actors involved. Simulations suggest that model predictions decisively change when bilateral exchange of approval is taken into account. Under a wide range of conditions learning actors more easily cooperate in a bilateral exchange relation than in the multilateral compliance-approval exchange. As a consequence a highly cohesive group may emerge while simultaneously social control is ineffective. Implications for empirical research and for theories of informal control are discussed.

### **3.4.4 Achim Sydow: Parallel Simulation of Distributed Systems: Ozone Analysis**

The paper describes an example how to use parallel computers for the simulation of distributed systems.

In recent years increasing computing capacity has made it possible to develop numerical models enabling the transport and chemical transformation of air pollutants to be simulated,

while at the same time taking into account complex flow and dispersion characteristics. An air pollution simulation system is developed at GMD FIRST in order to support users in governmental administrations and industry in operative decision making (smog management) as well as regional planning (e.g. environmental compatibility tests). The components of the simulation system are:

- parallelly implemented simulation models (meteorology, transport, air chemistry)
- data bases for model input and simulation results
- graphic user interface for spatial data visualization.

The basis for the simulation of air pollutants dispersion is the acquisition and selection of the input data for the models, and its storage in data bases. There are three groups of data necessary:

- topographical data (surface elevation and land utilization),
- meteorological data (geostrophic wind, vertical profiles of temperature and pressure, etc.),
- emission data (sources of industry, private households, and traffic).

Currently the decision support for users of the simulation system is limited to the 2D visualization of the simulation results obtained from scenario analyses. Future improvements will allow a 3D visualization, statistical analyses, and optimizations. The kernel of the system are the numerical models for meteorology, air pollutants transport, and air chemistry (especially models for ozone production and decay). Simulations with these complex meteorological and air-chemistry models are very computing time intensive. To offer a user results of case studies in an acceptable time or to make a smog prognosis possible (computing time less than simulation time) the simulation system has been parallelized. Since the model area exists in form of a three-dimensional grid, an inner parallelism of the models is already given. Because of physical characteristics in the vertical, the parallelization has been done by a grid partitioning of the model area in horizontal direction.

By means of the simulation system on behalf of the environmental department of the state government of Berlin and the ministry for environment of the state Brandenburg summer smog analyses were carried out concerning the duration of the measuring campaign FLUMOB in July 1994. On behalf of Greenpeace the influence of emissions caused by traffic in Munich on the ozone concentration in the Munich area was analyzed for a typical midsummer day in 1994. The visualization of the simulation results shows in both cases a significant ozone trail on the lee-side of the urban area resulting from man-made emissions of ozone precursor substances. This phenomenon could be confirmed by measurements. The maximum ozone concentrations is reached in some distance (about 25 km) from the city centers. By means of the simulation system various scenario analyses were carried out to study the influence of emission reduction measures on the amount and shape of the ozone concentration. Because of the validation of the analyses by measuring campaigns the developed air pollution simulation system has successfully finished its phase of introduction, and has showed that it is well-suited as a valuable and cost-effective tool for decision support of environmental agencies concerning such topics. The scenario analyses show that local emission reduction measures separately performed reduce the area of very critical ozone concentration (ozone maxima). To reduce the macroscale background ozone concentration permanently high for summer smog periods drastic measures at least on regional, but better on national or European scale are necessary. These results were also confirmed by the local ozone experiment carried out in the region of Heilbronn in midsummer 1994.

### **3.4.5 Ulrich Mueller: Finding Optimal Life Courses with Stochastic Dynamic Programming**

For causal analysis in demography, individual longitudinal data are indispensable. Life table and transition rate methods, however, allow the analysis of single events only, they do not capture the

character of the human life course as a adaptive sequence of transitions. Using concepts from evolutionary life history research, a new approach to analyzing whole life courses is presented: from measuring trade-offs between life course traits identifying optimal life courses with dynamic stochastic programming, and modeling the effect of covariates as determining deviations from the optimal sequence.

Two central issues of simulation techniques are addressed: the use of simulation for solving complex optimization tasks; and the problem of checking the adequacy of models by testing the results of simulation runs against real data.

### **3.4.6 *Ramzi Suleiman*: Towards a refined simulation of cooperation and competition**

The possibility of cooperation between rational actors has been extensively studied in economics and in other social sciences. The application of simulation, especially cellular automata based ones, seems to be a useful tool for studying the evolution of cooperation under various environmental and interactional conditions.

The present paper reviews some of this simulation effort and suggests the following objectives for future simulations:

- It is argued that the learning dynamics must be refined to include more aspects of bounded rationality.
- More emphasis should be put on studying  $N$ -person games.
- More should be done to study the emergence of group clustering and the interactions between existing social groups.

## **3.5 Distributed Artificial Intelligence**

### **3.5.1 *Jim Doran*: Simulating Societies Using Distributed Artificial Intelligence**

In this paper I argue that precise computer-based models can help build much needed stable theory of human societies, but that to be fully effective they must explicitly embody not merely processes of social interaction, but also the major components of individual cognition: (bounded) rationality, belief and misbelief, and affect.

Distributed AI is concerned with the design and creation of useful “societies” of computational agents, each of which has (limited) cognitive abilities. Such societies may serve as models of the type we require. They may be used experimentally: a relatively limited set of assumptions is built into the model, and the phenomena that emerge from the assumptions explored.

A number of types of DAI computational agent architecture have been designed and developed, both simple and complex and including some intended to capture aspects of “emotional” states. Various mechanisms of inter-agent communication and coordination have also been studied.

Particular examples of DAI based modelling cited in the paper for illustration are: a model of group decision making in the Tsembagan people of New Guinea, a model of hierarchical organisation addressing issues of misbelief and affect, and models of collective misbelief and its functional significance.

Finally I examine the relationship between DAI based models and models of other types, and discuss difficulties which must be overcome before the potential of DAI based models may be fully realised,

### **3.5.2 Rosaria Conte and Cristiano Castelfranchi: Simulating multi-agent interdependencies. A two-way approach to the Micro-Macro link**

In this work, DEPNET, a DAI system that calculates the dependence relations in a population of artificial agents situated in a common world, is applied to the problem of the micro-macro link (MML). By MML problem it is here meant how macro-level social phenomena, coalitions, organizations, etc. emerge from and are implemented into the micro-level behaviour. The work is based upon the assumption that agent cognition plays a fundamental role in combining Micro and Macro. Therefore, an AI-based computational methodology is regarded as useful for addressing the MML problem in that it provides some basic agent architecture. DEPNET will be applied to examine: how complex structures of interdependencies emerge from agents endowed with internal architectures, however simple, and situated in a common world; and how these structures in turn determine other properties of the system at both the individual and collective levels. After a brief presentation of the formal model of dependence upon which DEPNET is based, its three main facilities are described: the agent edition module describing the agency of the system in terms of goals, actions, and resources; the dependence network constructor; and the dependence situations constructor, which describes types of dependence situations in the network. Three dynamic properties of the system will be shown to result from the simulations run: the emergence of quantitative inequalities, due to dependence relations, from agents endowed with heterogeneous but equivalent goals and resources; the ups and downs of the agents' fates due to their social mobility; the emergence of the agent power of negotiation in terms of the number of agents depending on oneself as compared to the number of agents one is dependent upon: the larger this intersection, the higher one's power of negotiation (that is, the better one can sell on the social market).

### **3.5.3 Klaus Manhart: Artificial Intelligence Modelling: Data Driven and Theory Driven Approaches**

Compared with conventional computer models, AI based modelling offers a wide range of decisive advantages for the social sciences: theoretical knowledge does not have to be quantified, is coded explicitly and modularly and its conclusions can be explained and justified. AI or knowledge based systems can be used in the social sciences for both theory driven and data driven model building. In the case of the theory driven approach, knowledge based modelling allows the translation of nearly any qualitative theory into a symbolic program in order to discover new conclusions or to investigate the logical features of the theory. With the data driven approach, an attempt is made to replicate empirical data with generate and test programs as well as possible and, in this way, to discover theoretical mechanisms inductively. The transitive graph model is used to illustrate how theoretically substantial conclusions and hypotheses are generated with the aid of a mixed approach, which fluctuates between theory and data.

### **3.5.4 Adelinde Uhrmacher: Object-Oriented and Agent-Oriented Simulation: Implications for Social Science Application**

The description of entities and their interaction is central to object-oriented and agent-oriented simulation as well. Object-oriented and agent-oriented techniques lend themselves to multi-level simulation of societies, representing individual and collective actors as objects or agents, respectively. The question rises to what extent does agent-oriented deviate from object-oriented simulation and which are the possibilities each of them offer in capturing phenomena of modern societies. Often the distinction between objects and agents seems to be reduced to a question of

naming. However, the simulation of agents with sophisticated deliberative capabilities exceeds the frame of object-oriented simulation systems. Those agents require specific mechanisms to structure and expand the knowledge of common objects by internal models about the world they are interacting with. At this point, we find an interesting correspondence between agents and variable structure models. Those models that entail in their description the possibility to change their own structure rely heavily on knowledge about their environment for taking action. Referring to concepts in individualistic social science and symbolic interactionism, the relationship between objects and agents and the mediating role of variable structure models are explored more closely. The simulation system AgedDEVS which has been developed to support variable structure models in an object-oriented discrete event framework is used to illustrate some of these reflections.

### 3.5.5 *G. Nigel Gilbert: Simulation as a research strategy*

This talk, which concluded the seminar, aimed to draw out and summarise the main themes that emerged during the conference. The first theme concerned the value of simulation as an approach to social science. Simulation, in contrast to more conventional ‘variable-centred’ methodologies, is concerned to explicate the mechanisms of social processes, answering ‘how’ and ‘why’ questions about the relationships between observable behaviour. It does this by studying the connections between ‘micro’ (usually individual) level behaviour and macro-level properties. These connections may be two-way, with micro-level processes generating macro-level relationships, and the macro-level affecting the micro processes.

While theoretical concerns often dictate that the appropriate level of micro analysis is the individual, the consequence is that individuals’ cognitive (and emotional) processes are treated as a ‘black box’. However, some argue that this is inadequate, as sub-individual processes cannot properly be represented by any simple function (for example, it is difficult to account for learning, memory, goals, bounded rationality, etc.). This is an argument for simulation using agents that have some simple cognitive capabilities.

One way of allowing for sub-individual processes is to add a degree of randomness to agents’ simulated behaviour. Stochastic models are also used to avoid imposing unwanted temporal or sequential effects (e.g. in stochastic updating procedures for cellular automata), and to demonstrate the robustness of emergent properties in the face of variations in model parameters.

A second theme of the meeting was the issue of the appropriate methodology to use for simulation research. A number of conflicting proposals were made, but these could be simplified to recommendations to use either a deductive or an inductive strategy. Deduction requires the analyst to begin with a general theory, to formalise some part of the theory to yield a specification, to implement this to give a model (often a computer program), and then to run the model to generate simulated data. This can then be used to validate the model. Finally, the findings of the research need to be interpreted in terms of the original theory.

A recurring issue during the conference was how to validate models. Sensitivity analysis could be helpful, but the number of parameters in most models meant that a thorough sensitivity analysis is usually impracticable. Another approach is to compare simulated data with data collected from human societies. However, since many models can be found to fit the same data, since the assumptions of statistical tests of goodness of fit are often violated, and since a comparison of simulated and collected data tests the model, rather than the theory, this approach is also not adequate. It was argued that the best strategy is to devise critical experiments which test specific and significant aspects of the theory; and that, rather than focusing on goodness of fit, the aim should be to generate ‘illuminating’ conclusions which would aid in understanding the social world.

Some examples of this ‘illumination’ were suggested, drawn from the papers presented at the conference. In brief, these were:

- Diversity of culture, abilities and interests is functional for societies’ survival.
- Correlations between individual attributes (e.g. opinions) may be due to clustering, rather than causal links.
- The same processes can lead to different consequences in small and large groups.
- Minorities will not always be overwhelmed by majorities
- Complex individual strategies lead to more cooperation than simple ones.
- Mis-perception of the state of other agents (in an organisation) can be functional (for the organisation).

An alternative to deduction is the inductive paradigm. This recommends collecting data from some domain of interest, generalising the data and developing a specification from the generalisation. The specification is used to construct a model which is run to examine the model’s implications. This then yields a theory about the domain.

While, at least in sociology, the deductive approach is linked to a concern with social structure, macro properties and formal models, and is usually accompanied by a positivist or realist philosophy of science, the inductive approach is more often associated with an emphasis on meaning, interaction and context, and a reliance on constructivist or relativist philosophies of science.

The third theme of the meeting was the demands simulation research makes on computing technologies and toolkits. Most current simulations, with some notable exceptions, have relatively modest requirements for processing power. The needs of researchers for software tools are less easily satisfied. In particular, there is a need for high level toolkits that provide a flexible and extensible specification language capable of symbolic and numerical processing, and which have built-in and easy to use facilities for interactive graphical output in order to display the results of simulation.

## 4 Summaries of Informal Discussions

### 4.1 Environments and Languages to Support Social Simulation *Summary by Nigel Gilbert*

*Research on social simulation inevitably involves the construction of a simulation program, a representation of a model that can be executed on a computer. An informal discussion was held around the fountain in front of the Schloß on a sunny Tuesday afternoon during the seminar week to consider the options available for implementing simulation models.*

The participants had experience of two approaches to this issue. On the one hand, some participants used or, more commonly, had developed a simulation toolkit or environment: systems that enabled a variety of simulation models to be specified and run. Others had developed simulations using one of a number of general purpose programming languages such as C, Pascal, SmallTalk, Fortran, or Prolog, sometimes augmented by user interface libraries or extensions (e.g. Visual C++, NextStep).

The advantage of using a simulation environment are that less effort and less programming skill are required to implement a simulation, graphical interfaces for input and output are provided, and the code is more easily understandable by other researchers and students. The disadvantages include relatively slow execution speed (since they are based on interpretation, rather than compilation, of the code) and some limitations on the types of models that can be implemented. It is also the case that at present these environments are few in number and, because there is no commercial market for them, they tend to be poorly supported and sometimes have bugs.

The advantages of using a general purpose programming language are that there are no restrictions on the type of simulation that can be created with them and that, with care, relatively efficient programs can be built (important for simulations involving large numbers of units). However, the code is difficult for others to understand and the user interface has to be created anew for each model. (Examples of simulations where more than half of the code was devoted to the user interface were quoted).

Three ways of overcoming the limitations and disadvantages of these approaches were suggested. First, high level tools such as SAS, Mathematica, and MathLab could be used to build simulations. These offered flexibility and excellent graphical display options. However, there were slow and often difficult to adapt to the task of running simulations. Secondly tools such as spreadsheets (e.g. EXCEL) could be used to provide graphical output to simulations built with general purpose programming languages. However, they were unsuitable for simulations that required interactive, continuous, or real-time output. Thirdly, class libraries offering graphical output modules could be used with object-oriented systems such as C++ and SmallTalk. However, these libraries tended to be difficult to acquire, poorly documented, and difficult to learn to use.

Toward the end of the discussion it was agreed that the way forward would be to follow the simulation environment approach, but that such environments would need to be flexible, extensible, and would have to offer all those facilities which were generally accepted to be needed for social simulation. The field was still too new for there to be any consensus about what these facilities should be, and thus it was too early for a general simulation environment to emerge. We could expect it do so over the next decade. Meanwhile MIMOSE provided a good starting point, while recognising that it suffered at present from not being sufficiently easily extensible and from the understandable inability of its developers to provide the degree of support needed if it were to be very widely used.

## 4.2 Computer Simulation and Social Sciences: On the Future of a Difficult Relation *Summary by Klaus G. Troitzsch*

*Research on social simulation is obviously not mainstream; only a few journals devote a small part of their pages to simulation, at sociological congresses less than five percent of all talks are given by simulationists. An informal discussion invited by Georg Müller was held in Arms Hall of the Schloß, all participants equipped with lots of strawberry cake and whipped cream on a sunny Thursday afternoon during the seminar week to consider why social simulation has not made greater contributions to the development of social science.*

In the last few decades social science experienced a rapid growth in the usage of statistical models (from factor and cluster analysis to structural equations modelling), but dynamic modelling with the help of computers has always been of minor importance. Systems Dynamics modelling, invented in the late sixties, was soon abandoned, perhaps because it did not guarantee a scientific career. Micro and multilevel modelling yields simple models, which may be good models in the sense that they are theory related as is the case with Rational Choice related approaches), but they are not necessary similar to reality and sometimes even “counterintuitive” — which makes it difficult for model builders to find an enthusiastic audience for this kind of models. On the other hand, modelling (and theory building) is always abstraction, thus closeness to reality cannot be expected from abstract models.

Why aren't social scientists model builders? One answer was that fashion in sociology shifted away from science towards an explicitly non-scientific relativism, so the climate is against social simulation. Another answer was that tools for dynamic modelling are missing: regression and structural equation models, i.e. parameter estimation in static models work well; in this environment of statistical procedures even inconsistent models in the heads of users of these tools are fit into the Procrustes bed of widely distributed ready-to-use linear and static models. The gap between dynamic modelling and mainstream data analysis opens even wider as longitudinal micro level data (the empirical analogue to micro and multilevel simulation results) have only been widely accessible for very few years. Thus it does not come as a surprise that the first simulation results which were accepted by non-simulationists (although rather by practitioners than by scientists) were short time predictions in demography, tax and transfer analysis yielded by microanalytical simulation models (MSM), although they are not fully dynamical but give only first round effects and explicitly assume that people do not react on (and do not change) the state of the macro level, and although they are rather based on “detailed technical knowledge” than on accepted theory.

Social simulation seems to have been used for two conflicting purposes:

- for advising and for decision support, i.e. for practical reasons, like in Systems Dynamics models and in microanalytical simulation models (MSM): results were believed until advice taken from those models led to disaster;
- for ex post understanding, i.e. for intellectual reasons, as in the case of multilevel modelling, cellular automata, game theoretical simulations, and distributed artificial intelligence — whose results seem to find a growing, but still small audience.

Both audiences — practitioners and scientists, or: the general public and the academic public — cannot be satisfied at the same time. While practitioners may be attracted by (more or less) sound forecasts, the scientific public asks whether anything new comes out of the model. It might be better convinced when a better retranslation of model and simulation outcomes is achieved.



## 5 List of Participants

### Edmund Chattoo

University of Surrey at Guildford  
Dept. of Sociology  
Guildford GU2 5XMH  
Great Britain  
email: econec@vax.oxford.ac.uk  
phone: +44-1483-300800 X 3002  
fax: +44-1483-306290

### Rosaria Conte

Consiglio Nazionale delle Ricerche  
Viale Marx No. 15  
I-00137 Roma  
Italia  
email: rosaria@pacs2.irmkant.rm.cnr.it  
phone: +39-6-86090210  
fax: +39-6-824737

### Andreas Diekmann

Universität Bern  
Institut für Soziologie  
Lerchenweg 36  
CH-3012 Bern  
Schweiz  
email: ?  
phone: +41-31-654811  
fax: +41-31-654817

### Jim Doran

University of Essex  
Dept. of Computer Science  
Wivenhoe Park  
Colchester CO4 3SQ  
Great Britain  
email: doraj@sx.ac.uk  
phone: +44-1206-872-338  
fax: +44-1206-872-788

### Andreas Flache

University of Groningen  
Interuniversity Center for Social Science and  
Methodology  
Grote Rozenstraat 31  
NL-9712 TG Groningen  
Nederland  
email: a.flache@ppsw.rug.nl  
phone: +31-50-636261  
fax: +31-50-?

### Heinz P. Galler

Martin-Luther-Universität  
Wirtschaftswissenschaftliche Fakultät  
Große Steinstraße 73  
D-06099 Halle  
Deutschland  
email: galler@mliuwiws4.wiwi.uni-halle.de  
phone: +49-345-5118-133  
fax: +49-345-5118-?

### G. Nigel Gilbert

University of Surrey at Guildford  
Dept. of Sociology  
Guildford GU2 5XMH  
Great Britain  
email: Nigel.Gilbert@soc.surrey.ac.uk  
phone: +44-1483-259173  
fax: +44-1483-306290

### Rolf Grützner

Universität Rostock  
Fachbereich Informatik  
Albert-Einstein-Straße 21  
D-18059 Rostock  
Deutschland  
email: gruet@informatik.uni-rostock.de  
phone: +49-381-44224-123  
fax: +49-381-44224-?

### Rainer Hegselmann

Universität Bremen  
FB 9 Philosophie  
Postfach 330 440  
D-28334 Bremen  
Deutschland  
email: hegsel@mathematik.uni-bremen.de  
phone: +49-421-218-3034/3131  
fax: +49-421-218-4265

### Hans-Dieter Heike

Rechts- und Wirtschaftswissenschaften  
FG Statistik und Oekonometrie  
Technische Hochschule Darmstadt  
Residenzschloß  
D-64283 Darmstadt  
Deutschland  
email: heike@vb.vwl.th-darmstadt.de  
phone: +49-6151-16-5293  
fax: +49-6151-16-5553

### Dirk Helbing

II. Institut für theoretische Physik  
Universität Stuttgart  
Pfaffenwaldring 57/III  
D-70550 Stuttgart Deutschland  
email: helbing@theo2.physik.uni-stuttgart.de  
phone: +49-711-685-4930/4926  
fax: +49-711-685-3500

**Oliver Kirchkamp**

Universität Bonn  
Wirtschaftstheorie III  
Adenauerallee 24–26  
D–53113 Bonn  
Deutschland  
email: oliver@glider.econ3.uni-bonn.de  
phone: +49–228–73–7994  
fax: +49–228–73–7990

**Bibb Latané**

Florida Atlantic University  
Department of Psychology  
Boca Raton FL 33431  
USA  
email: latane@socpsy.sci.fau.edu  
phone: +1–407–278–4151  
fax: +1–407–276–9364

**Wim B.G. Liebrand**

Rijksuniversiteit Groningen —SWI—  
Grote Rozenstraat 15  
NL–9712 TG Groningen  
Nederland  
email: w.b.g.liebrand@ppsw.rug.nl  
phone: +31–50–63–6348  
fax: +31–50–63–?

**Klaus Manhart**

Universität Leipzig  
Institut für Soziologie  
Augustusplatz 9  
D–04109 Leipzig  
Deutschland  
email: manhart@rz.uni-leipzig  
phone: +49–341–719–3053  
fax: +49–341–719–3073

**Allan Mazur**

Syracuse University  
Public Affairs Program  
Syracuse NY 13244  
email: amazur@mailbox.syr.edu  
phone: +1–315–443–?  
fax: +1–315–443–1075

**Joachim Merz**

Universität Lüneburg  
Forschungsinstitut Freie Berufe  
Scharnhorststraße 1  
D–21335 Lüneburg  
Deutschland  
email: ffb@rzuws13.uni-lueneburg.de  
phone: +49–4131–78–2051  
fax: +49–4131–78–2059

**Michael Möhring**

Universität Koblenz–Landau  
Institut für Sozialwissenschaftliche Informatik  
Rheinau 1  
D–56075 Koblenz  
Deutschland  
email: moeh@informatik.uni-koblenz.de  
phone: +49–261–9119–477  
fax: +49–261–9119–498

**Péter Molnár**

II. Institut für theoretische Physik  
Universität Stuttgart  
Pfaffenwaldring 57/III  
D-70550 Stuttgart Deutschland  
email: molnar@theo2.physik.uni-stuttgart.de  
phone: +49–711–685–4918/4926  
fax: +49–711–685–3500

**Georg Müller**

Université de Fribourg  
Chaire de Travail Social  
Route des Bonnesfontaines 11  
CH–1700 Fribourg  
Suisse  
email: georg.mueller@unifr.ch  
phone: +41–37–29 77 89  
fax: +41–37–21 2997 29

**Ulrich Mueller**

Universität Marburg  
Medizinische Soziologie  
Bunsenstraße 2  
D–35033 Marburg  
Deutschland  
email: mueller2@mailier.uni-marburg.de  
phone: +49–6421–28–6244  
fax: +49–6421–28–5660

**Hiltrud Niggemann**

Ruhr-Universität Bochum  
SFB 187  
Postfach 10 21 48  
D–44721 Bochum  
Deutschland  
email: hauptpbh@rz.ruhr-uni-bochum.de  
phone: +49–234–700–5172  
fax: +49–234–7094–1 12

**Daniel Probst**

Universität Bonn  
Wirtschaftstheorie III  
Adenauerallee 24–26  
D–53113 Bonn  
Deutschland  
email: probst@glider.econ3.uni-bonn.de  
phone: +49–228–73–9219  
fax: +49–228–73–?

**Hermann Quinke**

Gesellschaft für Mathematik und Datenverarbeitung mbH  
 Postfach 13 16  
 D-53731 St. Augustin  
 Deutschland  
 email: quinke@gmd.de  
 phone: +49-2241-14-2727  
 fax: +49-2241-14-?

**Nicole J. Saam**

Universität München  
 Institut für Soziologie  
 Konradstraße 6  
 D-80801 München  
 Deutschland  
 email: uf34201@sunmail.lrz-muenchen.de  
 phone: +49-89-2180-6215  
 fax: +49-89-2180-2922 ?

**Bernd Schmidt**

Universität Passau  
 Operations Research & Systemtheorie  
 Innstraße 33  
 D-94032 Passau  
 Deutschland  
 email: bschmidt@moni.fmi.uni-passau.de  
 phone: +49-851-509-341  
 fax: +49-851-509-798

**Ramzi Suleiman**

University of Haifa  
 Psychology Department  
 Haifa 31905  
 Israel  
 email: rsps854@haifauvm.haifa.ac.il  
 phone: +972-4-240-142  
 fax: +972-4-240-?

**Achim Sydow**

TU Berlin — GMD—FIRST  
 Forschungszentrum Innovative Rechnerysteme  
 und -technologie  
 Rudower Chaussee 5  
 D-12489 Berlin  
 Deutschland  
 email: sydow@first.gmd.de  
 phone: +49-30-63920  
 fax: ?

**Klaus G. Troitzsch**

Universität Koblenz–Landau  
 Institut für Sozialwissenschaftliche Informatik  
 Rheinau 1  
 D-56075 Koblenz  
 Deutschland  
 email: kgt@informatik.uni-koblenz.de  
 phone: +49-261-9119-472  
 fax: +49-261-9119-498

**Adeline Uhrmacher**

Universität Ulm  
 Fakultät für Informatik  
 Abteilung Künstliche Intelligenz  
 Postfach 40 66  
 D-89069 Ulm  
 Deutschland  
 email: lin@informatik.uni-ulm.de  
 phone: +49-731-502-4123  
 fax: +49-731-502-?